



**KHAI NGUYEN**

KẾT NỐI VỮNG BỀN

**DIN 3570**

**U - BOLT**

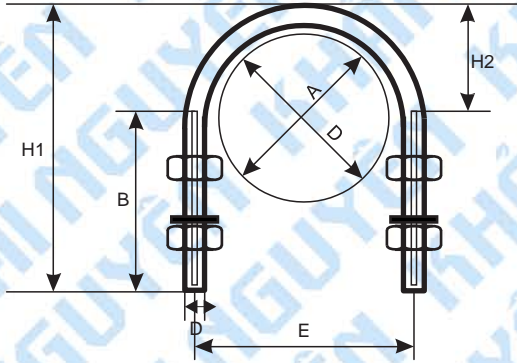

Form A

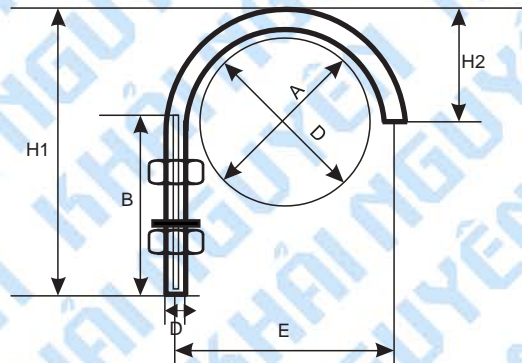

Form B

for tubes to nominal  $\varnothing$   
3" of 80 mm.

A	D=NOMINAL OF TUBE		D-EFFECTIVE OF TUBE		H1	H2	B	THREAD D	E	WEIGHTS IN KG PER 1000 P. (WITHOUT NUT & WASHER)	
	MM	INCH	METRIC	INCH IN MM						METRIC IN MM	FORM A
30	3/4	20	26.9	25	70	28	40	10	40	94	68
38	1	25	33.7	30	76	31	40	10	48	105	77
46	1 1/4	32	42.4	38	86	37	50	10	56	120	90
52	1 1/2	40	48.4	44.5	92	40	50	10	62	129	97
64	2	50	60.3	57	109	49	50	12	76	222	168
82	2 1/2	65	76.1	76.1	125	57	50	12	94	259	198
94	3	80	88.9	88.9	138	66	50	12	106	288	224
120	4	100	114.3	108	171		60	16	136	640	
148	5	125	139.7	133	191		60	16	164	727	
176	6	150	168.3	159	217		60	16	192	834	
202	7	175	193.7	191	249		60	16	218	958	
228	8	200	219.1	216	283		70	20	248	1698	
282	10	250	273	267	334		70	20	302	2028	
332	12	300	323.9	318	385		70	20	352	2350	
378	14	350	368	355.6	435		70	24	402	3820	
428	18	400	419	406.4	487		40	24	452	4290	
530		500	521	508	589		70	24	554	5220	