



KHAI NGUYEN

KẾT NỐI VỮNG BỀN

DIN 1587

HEXAGON DOMED CAP NUT

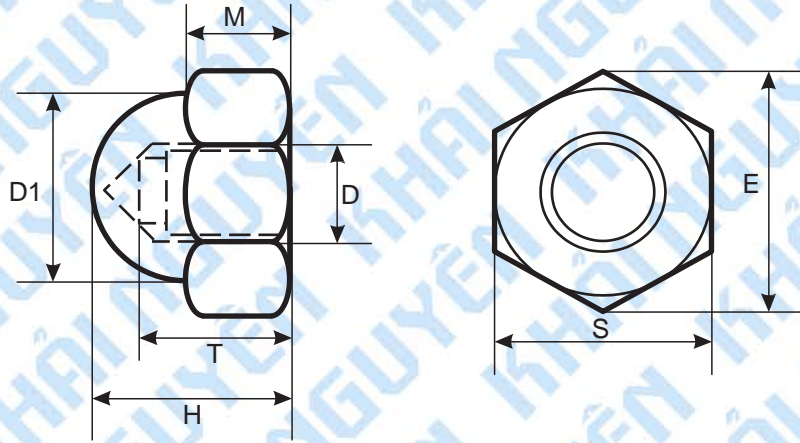

D	S	E	D1	H	T	M	WEIGHT IN KG PER 1000 PIECES	PACK
4	7	7.68	6.5	8	5.5	3.2	-	200
5	8	8.79	7.5	10	7.5	4	-	
6	10	11.05	9.5	12	8	5	4.66	
8	13	14.38	12.5	15	11	6.5	11.0	
10	16/17	17.77/18.90	15/16	18	13	8	20.1	100
12	18/19	20.03/21.10	17/18	22	16	10	28.3	
14	21/22	23.35/24.49	20/21	25	18	11	40	
16	24	26.75	23	28	21	13	54.3	
18	27	30.14	26	32	25	15	95.0	25
20	30	33.53	28	34	26	16	104	
22	32/34	35.72/37.72	31/33	39	29	18	129	
24	36	39.98	34	42	31	19	216	